

Top View

# 1600 Gal. (7200 L) Septic Tank

**Notes:**

1. Concrete: 35 mpa Air 5-7%
2. Weight: 6525 kgs.
3. Divider wall is monolithic cast.
4. Maximum cover: 1.5 m
5. Actual working capacity 7647 l
6. Litres per vert metre = 6268
7. For use in non-sulfate soils only
8. Tank is lifted using external rigging

Drawing Date: April 1, 2022

Acton Precast Concrete Limited  
Acton Ont. 1-800-461-1516

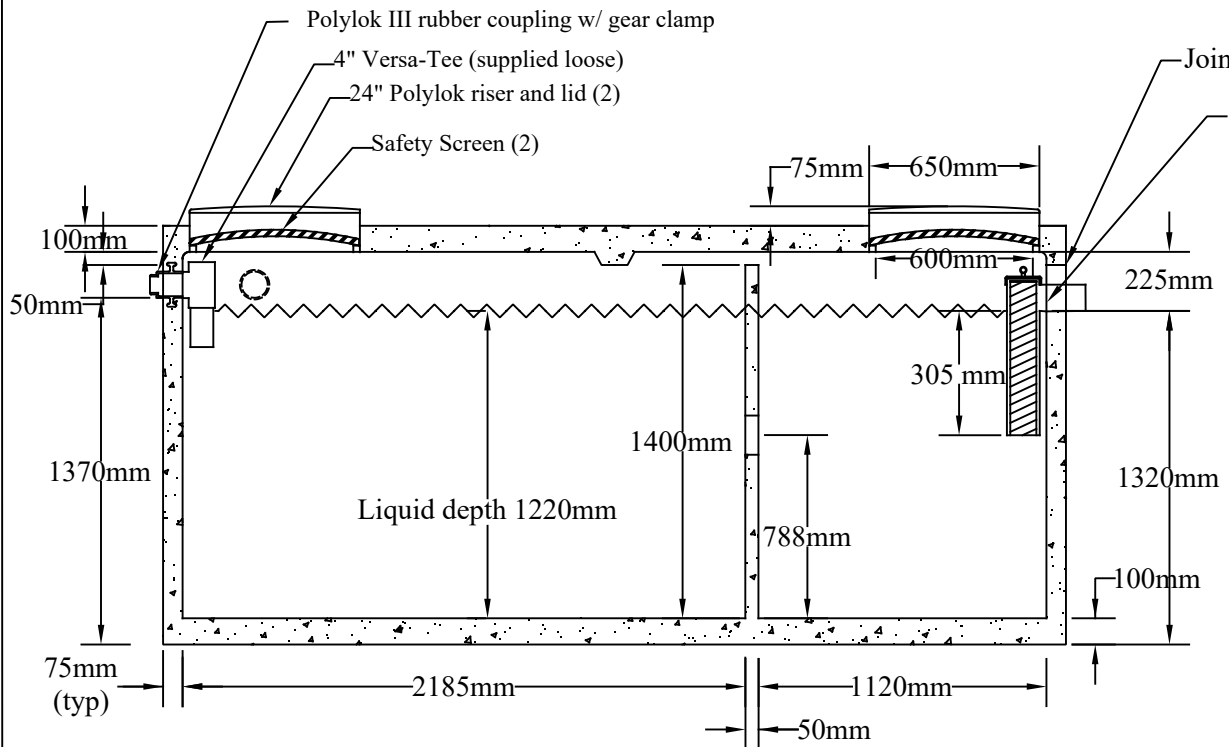

Section

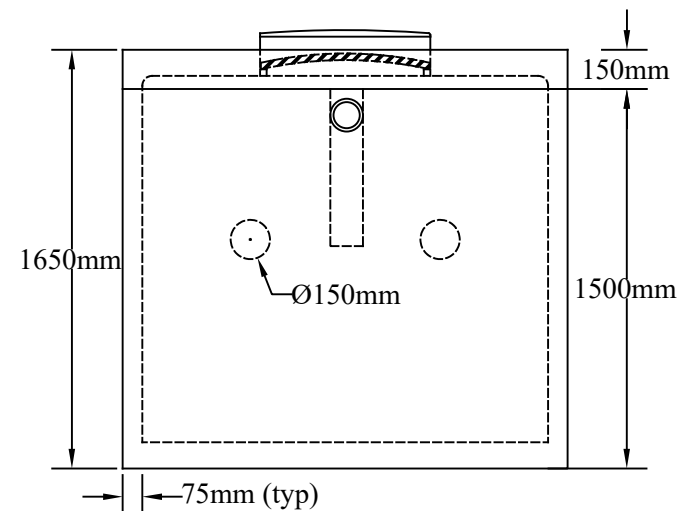

End View