

Top View

### 3500 Gal. (16000 l) Water Cistern

Notes:

1. Concrete - 35 mpa, Air 5-7%P
  2. Approx. weight - 13,000 kgs.
  3. Actual working capacity: 16,700 l
  4. Litres per vert metre: 9995
  5. Max. burial depth (cover) -1 Meter
  6. For use in non-sulfate soils only.
  7. Place on 200mm of compacted sand.
  8. Tank is lifted in 2 pcs. using "Burke" insert lifting system.
- Drawing Date: April 1, 2022

### Acton Precast Concrete Ltd

8949 Wellington Rd 50, Acton Ont. 1-800-461-1516

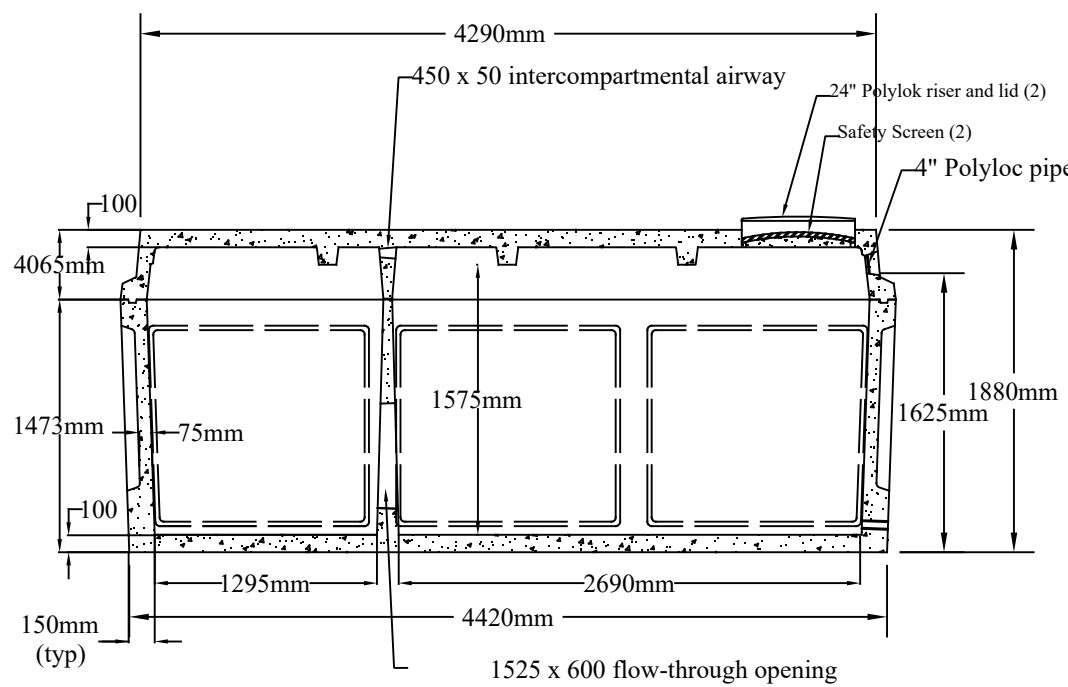

Section A-A

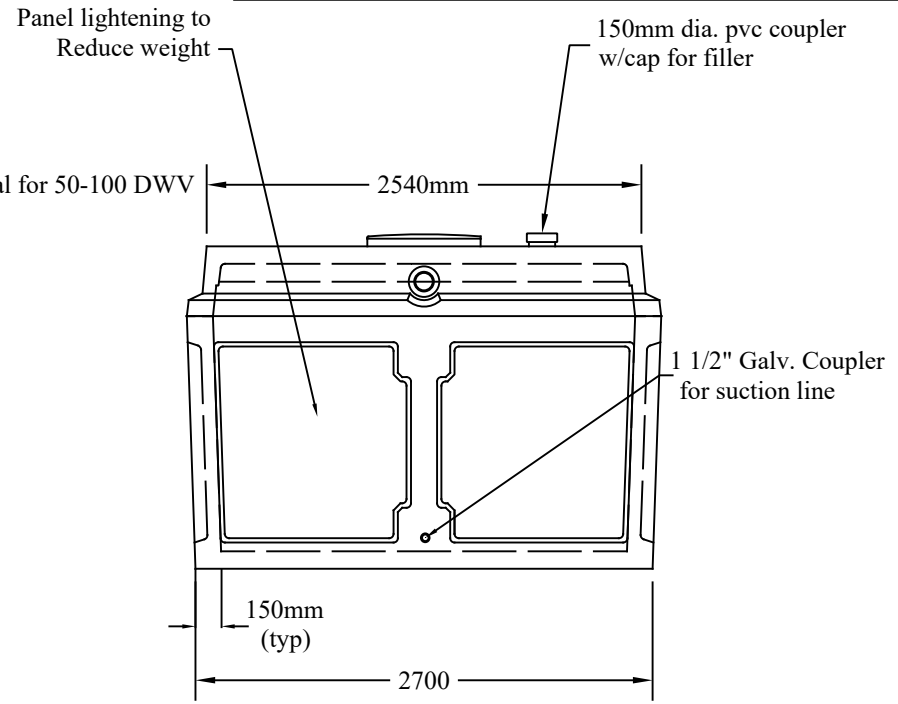

End View